

DATA SHEET

USB 3.0 Active Optical Cable USB-FC30AA

Contents

- ◆ Description
- ◆ Features
- ◆ Applications
- ◆ Technical Specifications
- ◆ Operating Conditions
- ◆ Drawing of Module
- ◆ Drawing of Cable Connection
- ◆ USB Pin Description
- ◆ Revision History

Optolinks

HQ Address
46 Corporate Park #130 Irvine, CA 92606
949-701-4742
info@VigilLink.com

Description

OPTICIS USB extension cable, USB-FC30AA, links the USB data up to 100m (328ft) without any repeater. USB-FC30AA provides the simplest way to link the USB device far from the host. Owing to the advanced VCSEL and PD, the USB protocol is capable of transmitting fully secured data with high cost efficiency by adapting hybrid fiber cable. Connected device must be self-powered to grant normal operation.

USB-FC30AA provides A plug to A plug. In addition, instead of using a pure fiber optical cable, to enhance its affordability, hybrid fiber cable with electrical wire is used, yet it meets Plenum grade. This offers convenient extension where there is no AC power supply adjacent at the end of the device. Furthermore, bi-directional transmission increases the convenience in such users do not need to distinguish TX/RX side of the connector. The cable is designed to be insensitive on the side.

A to B copper cable (15cm) and a locking housing are provided as an options for Type B device such as Camera, USB hub and etc.

Shipping Group:

- 1) One (1) USB-FC30AA AOC cable
- 2) User's Manual
- 3) USB A to USB B adapter copper cable (15cm)
- 4) Locking Housing

Features

- Compatible with USB 3.0 standards
- Transmits USB 3.0 data to 100m (328 feet) over hybrid cable.
- TX / RX insensitive design (two-way port)
- SuperSpeed USB 5Gbps data rate
- Operated by 5V source power
- USB 3.0 A type plug-in to A type plug
- No software installation required: Plug and Play

Applications

- Security / Monitoring over USB Camera
- Conference Room
- Control Room
- Offices / Factories
- Government
- Military

Technical Specifications

Parameter	Specification
Standard	USB 3.0
Power consumption	2W
Dimension (WDH)	40 x 16 x 9mm

Absolute Maximum Ratings

Stresses in excess of the absolute maximum ratings can cause permanent damage to the device. These are absolute stress ratings only. Functional operation of the device is not implied at these of any other conditions in excess of those given in the operational sections of the datasheet. Exposure to absolute maximum ratings for extended periods can adversely affect device reliability.

Parameter	Symbol	Min	Typ	Max	Unit
Supply Volt ¹	V _{CC}	-	5		V
Storage Temperature ¹	T _{st}	-20		+70	°C
Storage Relative Humidity ²	RH	10		90	%

Note:

1) Stresses listed may be applied without causing damage. Functionality at or above the values listed is not implied. Exposure to these values for extended periods may affect reliability.

2) Non-condensing environment.

Recommended Operating Conditions

Parameter	Symbol	Minimum	Typical	Maximum	Units
Bit rate	B	-	5.0	-	Gbps
Operation Temperature Range	T _o	0	-	50	°C
Supply Voltage	V _{CC}	4.8	5	5.2	V
Operating Current	I _{CC}	-	-	400	mA
Differential Impedance	R	-	90	-	Ohm

Physical Characteristics

Parameter	Description
Cable Type	Hybrid Cable MMF(OM3*4C) + 6C Electrical Wires
Cable Jacket	PVC Plenum
Cable Dimension	3.8 mm
Pull Strength	15 Kg
Minimum Bend Radius	38 mm (Under Load)

Drawing of Module

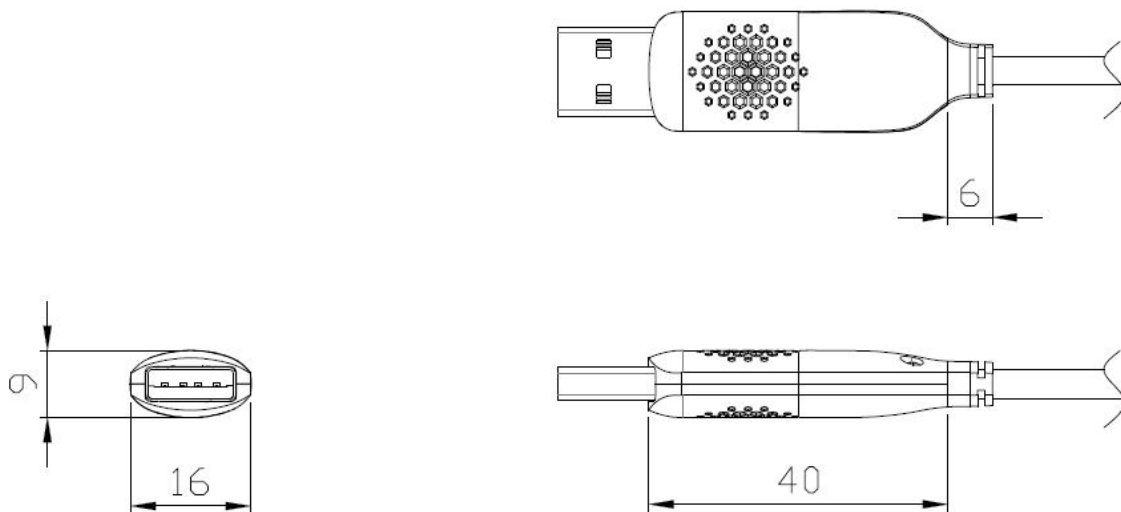

Drawing of Cable Connection

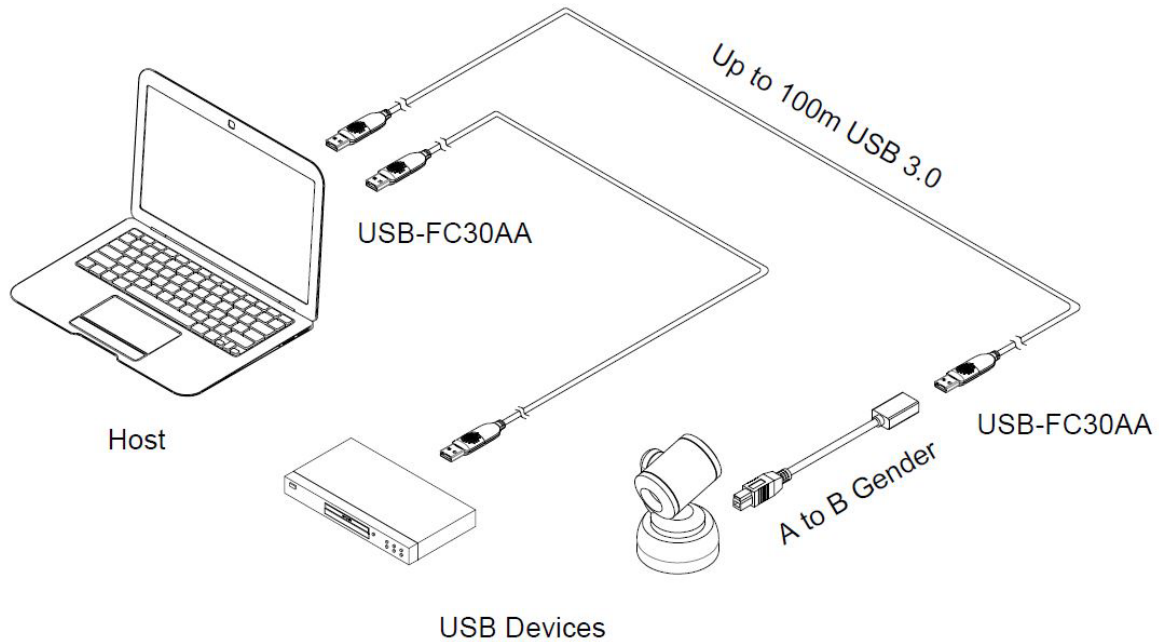

USB Pin Description

Pin	Symbol	Functional Description
1	VBUS	Power
2	Data-	NC
3	Data+	NC
4	GND	Ground for Power
5	SSRX-	SuperSpeed Receiver
6	SSRX+	SuperSpeed Receiver
7	GND DRAIN	Ground for signal
8	SSTX-	SuperSpeed Transmitter
9	SSTX+	SuperSpeed Transmitter

Revision History

Version	date	History
1.0	2020-07	Official version released
1.1	2020-11	Description modified